



## **CMT: Cold Metal Transfer**

MIG/MAG dip-transfer process for automated applications



PERFECT WELDING

# A hot&cold process makes the impossible possible.

## GENERAL REMARKS

### Some like it cold

There are materials and applications that cannot withstand the constant heat of a welding process. In order to avoid weld-pool drop-through, to be spatter-free, and to be amenable to metallurgical joining, they need lower temperatures. With CMT, this is now possible. CMT stands for Cold Metal Transfer. Of course, the term “cold” has to be understood in terms of a welding process. But when set against the conventional MIG/MAG process, CMT is indeed a cold process. Its characteristic feature: hot, cold, hot, cold, hot, cold. This alternating hot&cold treatment has been made possible by a new technological development from Fronius. And above all, by incorporating the wire motions into the process-control. The result: Spatter-free MIG/MAG robot welding and brazing for ultra-light gauge sheets from 0.3 mm. But let's take one thing at a time.



The welding system for the CMT process is optimally suited for all thin and ultra-light gauge sheets, for MIG-brazing of galvanised sheets, and for joining steel to aluminium.

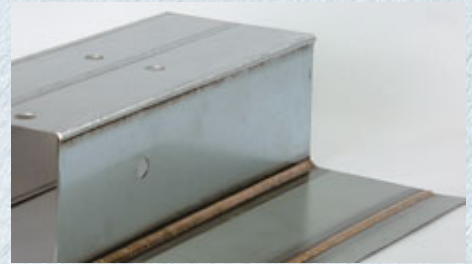

CMT-brazed joint between hot-dip and electrolytically galvanised sheet. Sheet thickness 1.0 mm, filler metal CuSi3.

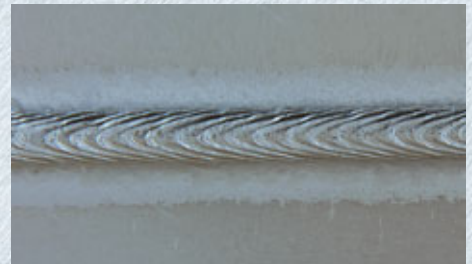

Fillet weld on 1.0 mm AlMg3 sheet with welding speed of 2.0 m/min.



Butt-weld, without weld-pool backing support, on 0.8 mm AlMg3 sheet.

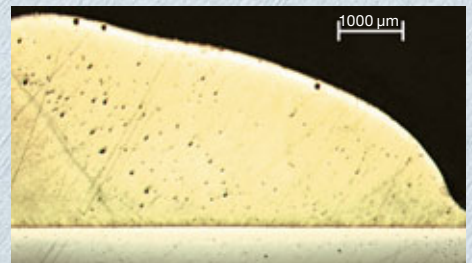

CMT joint between steel and aluminium. Welded on the aluminium side; brazed on the steel side.

# A giant step for welding technology.

## THE PROCESS

### A new process, defined by striking differences:

CMT is a wholly new development. Its launch was preceded by five years' research work. Yet more such innovative products are under development.

### Wire motions incorporated into process-control

This innovation addresses the entire welding process, as – for the first time ever – the motion of the wire is directly incorporated into the process-control. The digital process-control detects a short circuit, then retracts the wire so as to help detach the droplet. All digitally controlled. This is the first essential difference from conventional dip-transfer welding.

### Reduced thermal input

The second difference is the virtually current-free, off-circuit metal transfer. The wire moves forward, and as soon as the short circuit happens, it is pulled back

again. Automatically. In this way, the arc itself only inputs heat very briefly in the arcing period, after which the thermal input is immediately reduced. Hot, cold, hot, cold, hot, cold.

### Spatter-free metal transfer

And it is precisely this which leads to the third big difference: The rearward movement of the wire assists droplet detachment during the short circuit. The short circuit is controlled, and the short-circuit current is kept small. The result: spatter-free metal transfer.

And it is these crucial differences that make possible all those applications which used to call for a huge expenditure of time and effort: Spatter-free welding and brazing seams; welded joints between steel and aluminium; welding of ultra-light gauge sheets from 0.3 mm, also in butt-weld configurations without weld-pool backing support, etc.

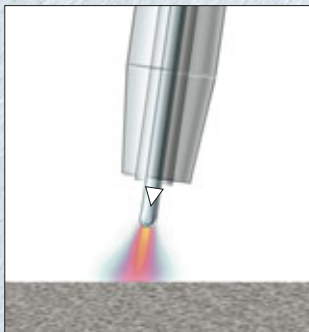

*During the arcing period, the filler metal is moved towards the weld-pool.*

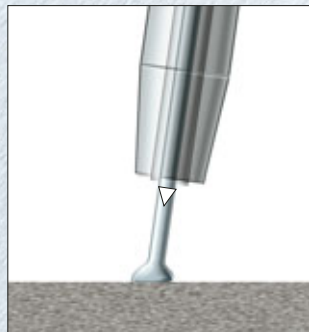

*When the filler metal dips into the weld-pool, the arc is extinguished. The welding current is lowered.*

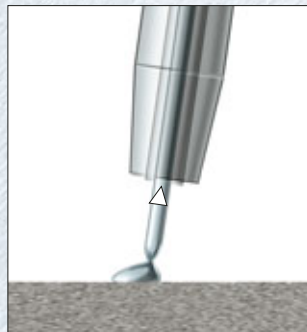

*The rearward movement of the wire assists droplet detachment during the short circuit. The short-circuit current is kept small.*

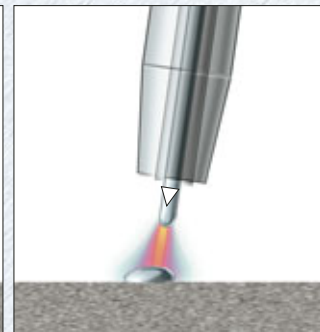

*The wire motion is reversed and the process begins all over again.*



The wire buffer decouples the front and rear wire-drives from one another and ensures smooth wire travel.

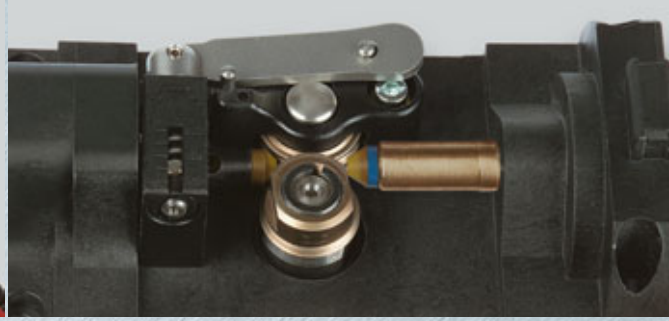

The new tension-lever system in the welding torch ensures constant and reproducible contact pressure.

## Entire system adapted to process

Before this innovative process could be realised in practice, new system components had to be developed. For the wirefeed, too, technologically novel approaches had to be taken.

To begin with, there are two separate wire-drives: The front one, the Robacta Drive CMT, moves the wire back and forward up to 70 times per second (as against only up to 5 times on the SyncroPuls), while the rear drive, the VR 7000 CMT, pushes the wire from behind. Both drives are digitally controlled. The front one, the Robacta Drive CMT, is gearless and is fitted with a highly dynamic AC servo motor. It ensures accurate wirefeed and constant contact pressure. What is new is that the torch hosepack can be uncoupled from the drive unit, permitting rapid changeovers with no need to reset the TCP (Tool Centre Point).

Moreover, a “wire buffer” is interposed between the two drives, to decouple them from one another and to provide additional storage capacity for the wire. In this way, the motion of the wire is achieved with practically no force being applied. Ideally, the wire buffer sits on the balancer, but it can also be mounted on the third axis of the robot. Compact and practical. No tools are needed to change the inner liner in the wire buffer either: Open the lid, old inner liner out, new one in, close the lid – that’s it.

## FACTS

The CMT process sets brand-new standards in welding technology

- assists droplet detachment by means of the wire-motions incorporated in the digital process-control
- reduces the thermal input by achieving almost current-free metal transfer
- ensures spatter-free metal transfer by controlling the short circuiting
- permits spatter-free MIG/MAG robot welding and brazing of ultra-light gauge sheets from 0.3 mm, and joining of steel to aluminium
- offers all the benefits of digital Fronius welding technology.

## UTILISATION

### Materials

The CMT process has a universal range of application. The specific know-how can be used for all materials.

### Applications

- automobile and allied vendor industries
- aerospace
- structural and portal work

# The success package

## THE SYSTEM

### CMT system configuration

As we've already mentioned, the CMT process is an absolutely new development. For this reason, there are several new features in the system as well – as compared with the other digital systems, for example. All the components were given a rethink,

adapted to the CMT process and harmonised with one another. Below you will find an overview of the system as a whole; in each case, of course, different design variants are possible.

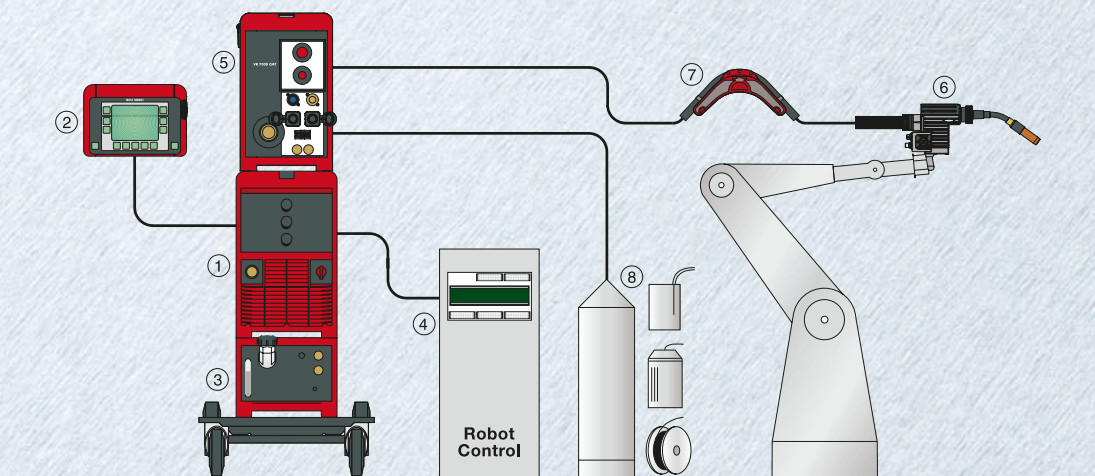

#### 1. TPS 3200 / 4000 / 5000 CMT power source

Fully digitised, microprocessor-controlled and digitally regulated GMA inverter power source (320 / 400 / 500 A) with an integral functional package for the CMT process.

#### 2. RCU 5000i remote-control unit

Remote-control unit with full-text display, weld-data monitoring with Q-Master function, easy-to-follow user guidance, systematic menu structure, user administration features.

#### 3. FK 4000 R cooling unit

Sturdy and dependable, ensures optimum cooling of water-cooled robot welding torches.

#### 4. Robot interface

Suitable for all customary robots, irrespective of whether these are addressed digitally, in analogue or via field-bus

#### 5. VR 7000 CMT wirefeeder

Digitally controlled wirefeeder for all common types of wirepack.

#### 6. Robacta Drive CMT

Compact robot welding torch with digitally controlled, gearless, highly dynamic AC servo motor. For precision wirefeed and constant contact pressure.

#### 7. Wire buffer

Decouples the two wire-drives from one another and provides additional storage capacity for the wire. For mounting on the balancer (preferably), or on the third axis of the robot.

#### 8. Wire supply

# All just right

## UTILISATION

### Wholly new applications open up

So what are some typical areas of application for the CMT process? Which metals and materials “prefer it cold”? All thin and ultra-light gauge sheets, from as thin as 0.3 mm; for MIG brazing of galvanised sheets, and for joining steel to aluminium. Until CMT, applications like these were only possible under difficult and labour-intensive conditions (e.g. weld-pool backing support), or users had to resort to different joining technologies altogether – which of course meant doing without all the advantages of a welded joint. With CMT, what used to seem impossible is now possible.

CMT sets brand-new standards in welding technology. This process is ideal for e.g. the automobile and allied vendor industries, the aerospace sector and for structural and portal work. Essentially, all automated or robot-assisted tasks are suitable. All customary base and filler metals can be used.

## COST EFFECTIVENESS, SERVICE, SAFETY

### Giving the costs the cold shoulder

Being a “colder” process overall, CMT makes a number of work-steps superfluous. Freedom from spatter, for instance, means no post-weld machining. Being able to butt-weld light-gauge sheets means there is no need for weld-pool backing support. High gap bridgeability means better process manageability and therefore suitability for automation.

And thanks to the multiprocess capabilities of the welding machine, you can also perform MIG/MAG standard and pulsed-arc welding as well as CMT. On top of all this, there are all the savings that result from the loss-free gas supply to the torch, the automatic cooling-unit cut-out, low open-circuit power, high efficiency, modular (and thus highly flexible) system principle, easy servicing, updates via laptop, etc. All the attributes that feature in the digital MIG/MAG systems do sterling service here as well, then.

### The very highest protection – as standard

Working with Fronius systems is definitely a very safe bet indeed. They all come with: S Mark, CE Mark, IP 23, earth fault-current watchdog, temperature-controlled fan. An additional benefit with the CMT systems is that because there is no spatter, fewer welding fumes are generated, which leads to less soiling in the welding cell.



#### FRONIUS USA LLC

Business Center-Eagle One, 10503 Citation Drive  
Suite 600 Brighton, Michigan 48116 USA  
Tel: +1 810 220 4414  
Fax: +1 810 220 4424  
E-Mail: sales.usa@fronius.com

#### FRONIUS INTERNATIONAL GMBH

Buxbaumstrasse 2, P.O.Box 264, A 4602 Wels  
Tel: +43 7242 241-0, Fax: +43 7242 241-3940  
E-Mail: sales@fronius.com

[www.fronius.com](http://www.fronius.com)